

# DC Golf Fan / 8CM



Model No.

**X0802512YG** 80x80x25mm

Frame and Impeller Material :  
Plastic (UL 94V-O)

Bearing system :  
Ball Bearing (B)  
Sleeve Bearing (S)  
Duro Bearing (DS)

Lead Wires :  
UL 1007 AWG 28 or equivalent.  
Red:+, Black:-

Model No. :  
X0802512YG

X=Bearing System, can be B, S or DS type..  
Y=Fan speed, can be L, M or H.

Net Weight :  
70g



## OUTLINE

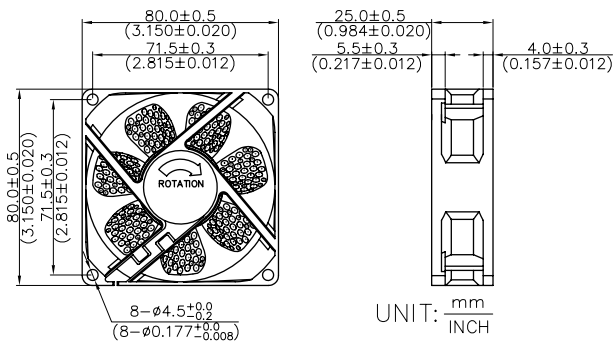

## CHARACTERISTIC CURVES

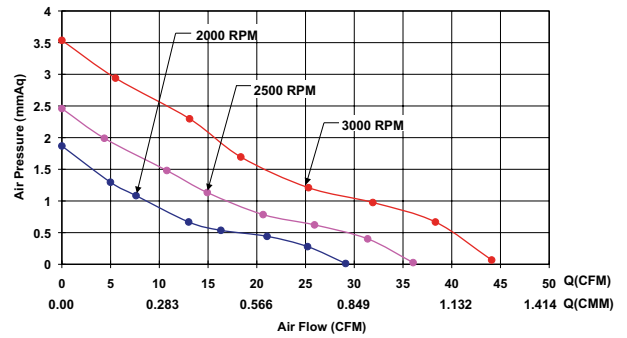

## SPECIFICATIONS

Item Model No.	Operating Voltage Range	Rated Voltage	Rated Current	Rated Input Power	Speed	Max Air Flow		Max Air Pressure		Noise
	V <sub>DC</sub>	V	Amp	Watt	R.P.M	m <sup>3</sup> /min	CFM	mmH <sub>2</sub> O	inH <sub>2</sub> O	dBA
B/S0802512LG	6~13.8	12	0.12	1.44	2000	0.82	29.11	1.86	0.07	19.5
B/S0802512MG	6~13.8	12	0.17	2.04	2500	1.02	36.04	2.46	0.10	22.6
B/S0802512HG	6~13.8	12	0.23	2.76	3000	1.25	44.09	3.54	0.14	30.3
DS0802512SLG	8~13.8	12	0.10	1.20	1000	0.34	11.84	0.40	0.02	10.2
DS0802512ELG	6~13.8	12	0.12	1.44	1400	0.52	18.35	0.83	0.03	11.7
DS0802512LG	6~13.8	12	0.18	2.16	2000	0.82	29.11	1.86	0.07	19.5
DS0802512HG	6~13.8	12	0.25	3.00	2800	1.17	41.15	3.30	0.13	29.9