

# DC Axial Fan / 9CM



Model No.

**X0922512Y** 92x92x25mm

Frame and Impeller Material :  
Plastic (UL 94V-O)

Bearing system :  
Ball Bearing (B)  
Sleeve Bearing (S)

Lead Wires :  
UL 1007 AWG 28 or equivalent.  
Red:+, Black:-

Model No. :

X0922512Y / X07138812Y

X=Bearing system, can be B or S type..  
Y=Fan speed, can be SL, EL, LL, L, M or H.

Net Weight :  
86.5g



## OUTLINE

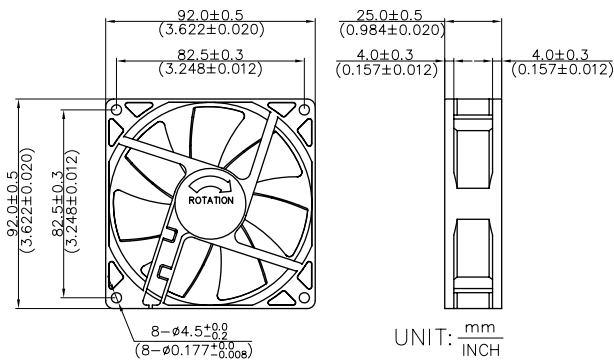

## CHARACTERISTIC CURVES

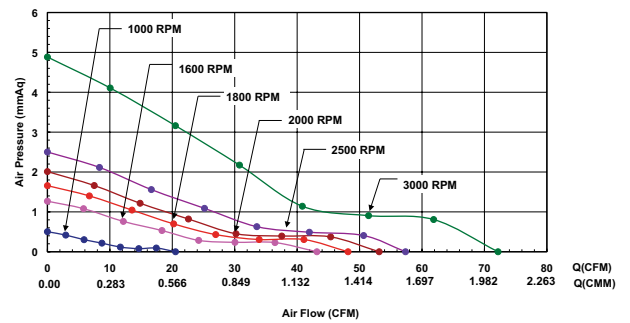

## SPECIFICATIONS

| Item<br>Model No. | Operating Voltage Range | Rated Voltage | Rated Current | Rated Input Power | Speed | Max Air Flow        |       | Max Air Pressure   |                    | Noise |
|-------------------|-------------------------|---------------|---------------|-------------------|-------|---------------------|-------|--------------------|--------------------|-------|
|                   | VDC                     | V             | Amp           | Watt              | R.P.M | m <sup>3</sup> /min | CFM   | mmH <sub>2</sub> O | inH <sub>2</sub> O | dBA   |
| B/FDB/S07138812SL | 10.8~13.8               | 12            | 0.18          | 2.16              | 1000  | 0.58                | 20.52 | 0.50               | 0.02               | 20.5  |
| B/FDB/S07138812EL | 6~13.8                  | 12            | 0.18          | 2.16              | 1600  | 1.22                | 43.16 | 1.27               | 0.05               | 21.0  |
| B/FDB/S07138812LL | 6~13.8                  | 12            | 0.18          | 2.16              | 1800  | 1.36                | 48.15 | 1.66               | 0.07               | 23.1  |
| B/FDB/S07138812L  | 6~13.8                  | 12            | 0.18          | 2.16              | 2000  | 1.50                | 53.14 | 2.01               | 0.08               | 25.9  |
| B/FDB/S07138812M  | 6~13.8                  | 12            | 0.27          | 3.24              | 2500  | 1.67                | 59.12 | 3.36               | 0.13               | 32.8  |
| B/FDB/S07138812H  | 6~13.8                  | 12            | 0.45          | 5.40              | 3000  | 2.04                | 72.18 | 4.88               | 0.19               | 39.0  |
| RLXX B/S0922512SL | 10.8~13.8               | 12            | 0.18          | 2.16              | 1000  | 0.58                | 20.52 | 0.50               | 0.02               | 20.5  |
| B/S0922512EL      | 6~13.8                  | 12            | 0.18          | 2.16              | 1600  | 1.22                | 43.16 | 1.27               | 0.05               | 21.0  |
| RLXX B/S0922512LL | 6~13.8                  | 12            | 0.18          | 2.16              | 1800  | 1.36                | 48.15 | 1.66               | 0.07               | 23.1  |
| RLXX B/S0922512L  | 6~13.8                  | 12            | 0.18          | 2.16              | 2000  | 1.50                | 53.14 | 2.01               | 0.08               | 25.9  |
| RLXX B/S0922512M  | 6~13.8                  | 12            | 0.27          | 3.24              | 2500  | 1.67                | 59.12 | 3.36               | 0.13               | 32.8  |
| RLXX B/S0922512H  | 6~13.8                  | 12            | 0.45          | 5.40              | 3000  | 2.04                | 72.18 | 4.88               | 0.19               | 39.0  |